

ARCO **HD**
HEAVY DUTY//





ARCO HD
HEAVY DUTY

AUTOBUS URBANI - TRAM - METRO - TRAGHETTI - NAVI HSC - ALISCAFI



NASCE PER RISPONDERE ALLE ESIGENZE
DI CHI CERCA
UN **SEDILE** DI **CATEGORIA ECONOMY**
STUDIATO NEI **MINIMI PARTICOLARI**

ARCO HD SI CONTRADDISTINGUE PER:



**ESTREMA
VERSATILITÀ**



**BASSI COSTI DI GESTIONE
E MANUTENZIONE**



**LEGGEREZZA
AI VERTICI DELLA CATEGORIA**



LA STRUTTURA A TRAVI IN LEGA DI ALLUMINIO OFFRE UN' AMPIA MODULARITÀ DI CONFIGURAZIONE E INSTALLAZIONE

**LE NUMEROSE CERTIFICAZIONI OTTENUTE,
REGOLAMENTO 118.03
CATEGORIA M2 E M3
IMO E HSC (3G FORCE)**

RENDONO QUESTO SEDILE **POLIVALENTE** E **FACILMENTE
ADATTABILE AD OGNI MEZZO DI TRASPORTO**

INNOVAZIONE



LEGGERO E RESISTENTE

Peso a partire
da 6.8 kg



ANTIVANDALO E CON BASSI COSTI DI MANUTENZIONE

Ogni componente può essere sostituito
singolarmente in pochi minuti



PERSONALIZZABILE

Seduta e schienali intercambiabili.
Ampia gamma di colori



ECOLOGICO

Completamente riciclabile e differenziabile
grazie alla modularità dei componenti.
Senza schiume poliuretaniche



POLIVALENTE

Grazie ai materiali utilizzati
può essere installato
sia all'interno che all'esterno

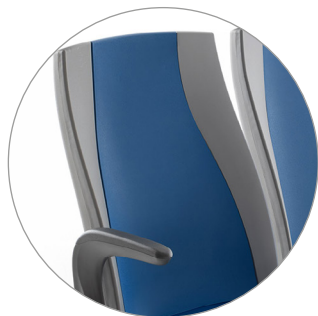

MODERNO, AGILE, ELEGANTE

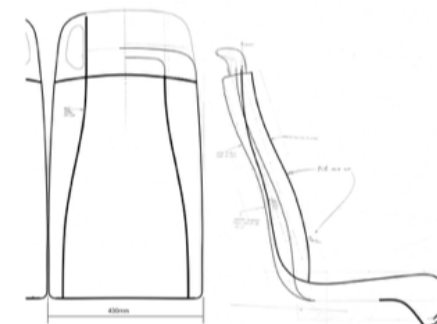
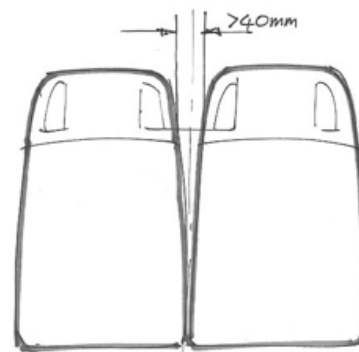

COMFORT



SISTEMA DI ASSORBIMENTO

Il supporto cuscino si flette ed assorbe vibrazioni ed urti

ERGONOMIA

Leggero e accogliente.
Progettato per rispettare le curve fisiologiche della colonna vertebrale

ABITABILITÀ

Grazie al design della monoscocca posteriore ed ai basamenti appositamente studiati, le gambe trovano ampio spazio anche con installazione ravvicinata

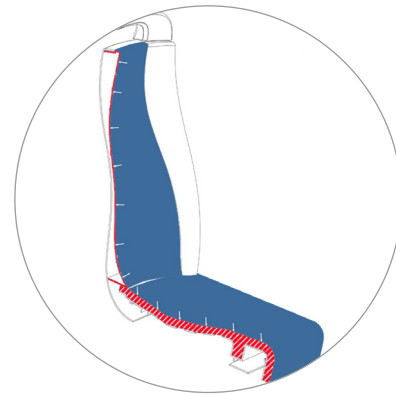
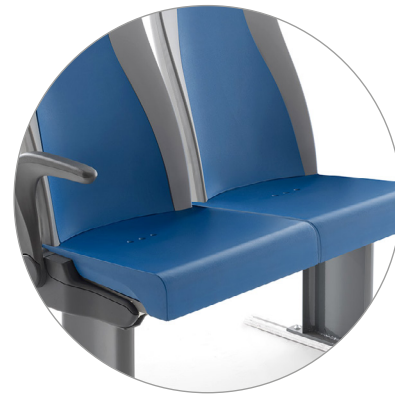

COMODITÀ SORPRENDENTE



MASSIMA
ABITABILITÀ

MATERIALI FACILMENTE LAVABILI E IGIENIZZABILI

Forme studiate per evitare che lo sporco si insinui nelle intercapedini

BASAMENTI LISCI E FUNZIONALI

Utili anche a prevenire la formazione di ruggine

CUSCINI SAGOMATI

Per il massimo comfort di viaggio

CINTURE DI SICUREZZA

Arrotolatore alloggiato sotto al cuscino. Il sedile è completamente libero sopra e sotto la seduta

*SEMPLICE,
ROBUSTO
E SPAZIOSO*



TECNOLOGIA

TELAIO STRUTTURALE

Il telaio perimetrale di tipo singleframe in acciaio è privo di giunzioni

TELAIO INFERIORE

Grazie ai longheroni in alluminio riduce la torsione ed aumenta la robustezza

FISSAGGI UNIVERSALI

Per basamenti, attacchi a parete, cantilever. Sistemi a sgancio rapido per PMR

MONOSCOCCA

Parte posteriore priva di giunzioni

LEGGERO

Solo 6,8 Kg.



CINTURE DI SICUREZZA A 2 E 3 PUNTI



Le cinture integrate scorrono all'interno della scocca. Facili da afferrare ed indossare

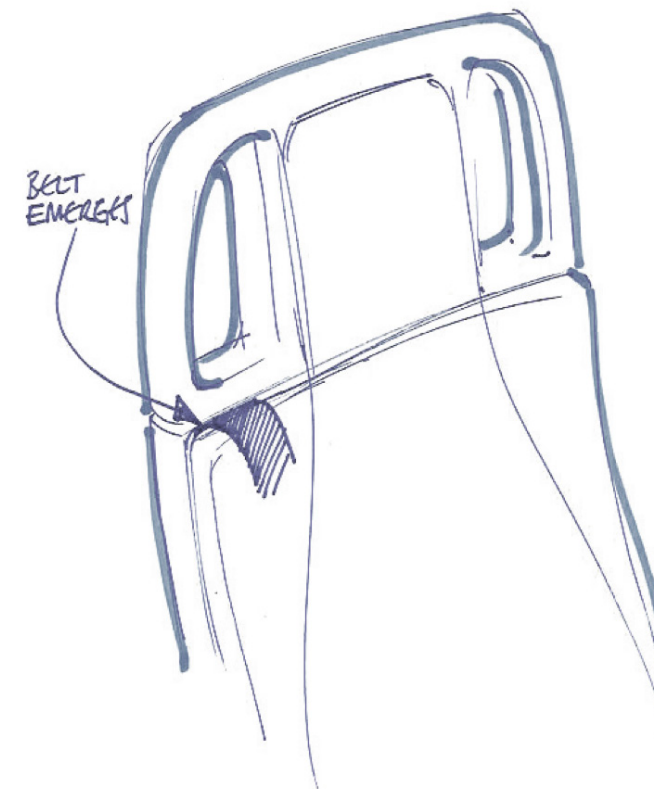



Politecnica
seat technology

Politecnica s.r.l.
Via Liguria, 46 - 60030
Monsano (An) Italy
Tel. +39 0731.619116
info@politecnicasedili.it
www.politecnicasedili.it